

Ruote dentate cilindriche e coniche costruite in materiale termoplastico NYLON PA 6 al 30% fibra di vetro colore grigio.

Caratteristiche

- Elevata resistenza meccanica, rigidità, durezza e tenacia
- Elevata resistenza alla torsione
- Buona resistenza alla fatica
- Elevato smorzamento meccanico
- Buona capacità di scorrimento
- Eccellente resistenza all'usura e alle sostanze chimiche
- Buone proprietà di isolamento elettrico

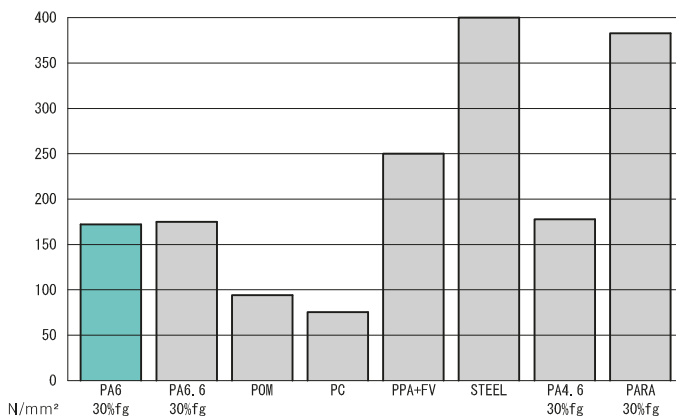

RESISTENZA ALLA FLESSIONE / FLEXING RESISTANCE

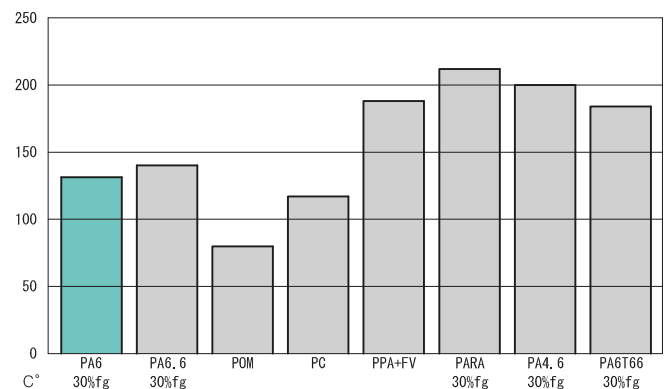

TEMPERATURA MASSIMA IN CONTINUO / MAXIMUM TEMPERATURE OF USE

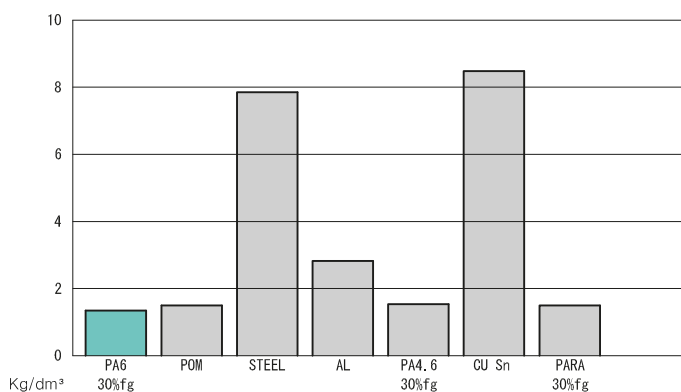

PESO SPECIFICO / SPECIFIC WEIGHT

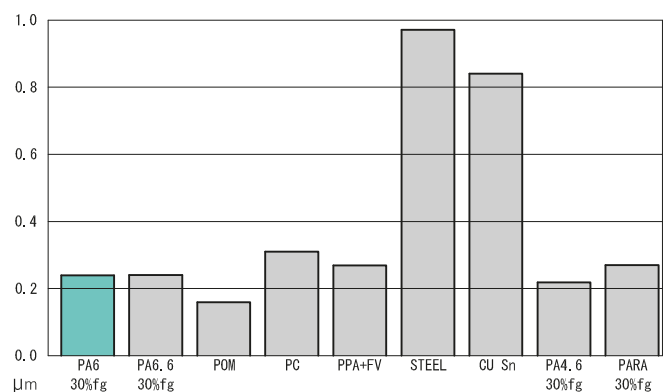

COEFFICIENTE D'ATTRITO / FRICTION COEFFICIENT



PIGNONI TENDICATENA - MATERIALE TERMOPLASTICO CHAIN-STRETCHER SPROCKETS - THERMOPLASTIC MATERIAL

I pignoni tendicatena vengono forniti pronti per il montaggio.
Sono composti da una ruota in materiale termoplastico montata su un cuscinetto a sfere.

Our chain-stretcher sprockets with ball bearing are supplied "ready for mounting".
They consist of a toothed wheel in thermoplastic material mounted on a ball bearing.

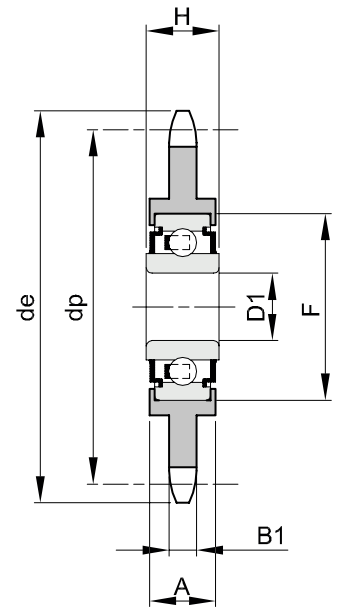
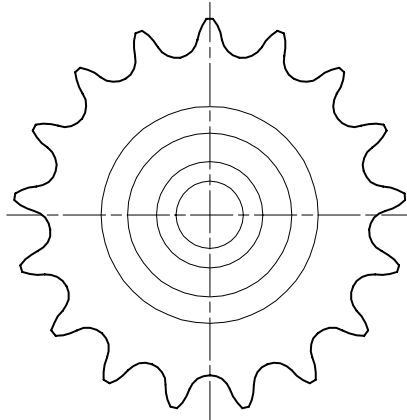

Materiale pignone: NYLON PA6+FV

Z	codice	passo	ISO	De	Dp	B1	A	D1	F	H	Kg.
21	PV364330021	3/8" x 7/32"	06B-1	67,6	63,91	5,3	16	16 ^{+0,26 +0,13}	40	18,3	0,10
16	PV364340016	1/2" x 5/16"	08B-1	69,9	65,10	7,2	16	16 ^{+0,26 +0,13}	40	18,3	0,10
18	PV364340018	1/2" x 5/16"	08B-1	78,0	73,14	7,2	16	16 ^{+0,26 +0,13}	40	18,3	0,11
15	PV364350015	5/8" x 3/8"	10B-1	83,2	76,36	9,1	16	16 ^{+0,26 +0,13}	40	18,3	0,13
17	PV364350017	5/8" x 3/8"	10B-1	93,3	86,39	9,1	16	16 ^{+0,26 +0,13}	40	18,3	0,14
13	PV364360013	3/4" x 7/16"	12B-1	87,8	79,59	11,1	16	16 ^{+0,26 +0,13}	40	18,3	0,12
15	PV364360015	3/4" x 7/16"	12B-1	99,8	91,63	11,1	16	16 ^{+0,26 +0,13}	40	18,3	0,13